

Magwell Model M510 Series, consists of a Diaphragm, the diaphragm deflection causes the piston to move. the movement of the piston is converted into appropriate calibrated rotary movement of the pointer through a magnetic connection. This type of piston model is used in applications where minor migration of the media from high pressure side (HP) to low pressure side (LP) is permitted. Instruments can be supplied with reed switches to initiate alarms, activate other equipment, or shut the system down. Two switches are used when high and low limits are desired. Gauge-switch models provide the user with both, gauge readout and switch operation.

Standard Features

- ◆ Diaphragm Operated Piston Design
- ◆ SS 316L Case from 2" to 6"
- ◆ Shatter Proof Safety Glass
- ◆ High Static Pressure Capability
- ◆ Weather Protection IP 65
- ◆ Dry or Liquid Filled Case
- ◆ Optional Reed Switches
- ◆ High Operating Pressure unto 200 bar

Applications

- ◆ Filtration Plants
- ◆ Flow Lines
- ◆ Hydraulics
- ◆ Measure Strainer Pressure Drop
- ◆ Power & Utility
- ◆ Water & Waste Water Treatment Facilities
- ◆ Other Critical Process Industries

Specification

Accuracy	: $\pm 2\%$ of the FSD
Range	: 0 ~ 0.25 to 0 ~ & 10 bar
Sensing Element	: Piston
Wetted Parts	: SS 316, Brass, Aluminum
Case Material & Dial Size	: SS 304, 2", 2.5", 3.5", 4", 4.5" & 6"
Mounting	: Direct, Front Flange, 2" Pipe or Surface Mounting
Max. Working Pressure	: 200 bar to Aluminum & Brass, 400 bar for SS316 & Monel
Max. Process Temperature	: 0 ~ 80°C Max
Body Material	: Aluminum, Brass, SS 316 & Monel
Seals	: Buna-N, Vitor & EPDM
Window	: Float Glass, Toughened Glass, Acrylic & Safety Glass
Connection	: 1/4" NPT(F), 1/4" BSP (F) , for others through Adapter
Porting	: In-line, Lower, Back
Over Range Protection	: Upto the Max. Working Pressure

Switch Options

- 1 or 2 SPSTs with a DIN plug
- 1 or 2 SPSTs with a terminal strip
- 1 or 2 SPSTs with a built in relay
- 1 or 2 SPDTs with a DIN plug
- 1 or 2 SPDTs with a terminal strip

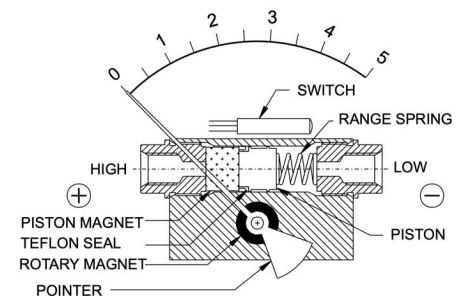

Ratings for Reed Switches

Switches	Contact Rating	Current	Voltage
SPST	10 VA ac (rms) or dc (Max)	0.5 Amp ac (rms) or dc (Max)	100 Vac/Vdc (max)
SPDT	3 VA ac (rms) or dc (Max)	0.3 Amp ac (rms) or dc (Max)	30 Vac/Vdc (max)

Rev-05.01

Model Selection Guide

Description	Coding
Size	1
2" (50 mm)	50
2.5" (63 mm)	63
3.5" (80 mm)	80
4" (100 mm)	100
4.5" (115 mm)	115
6" (150 mm)	150
Model	2
Diaphragm Operated, Piston Actuated Differential Pressure Gauge	M510
Body Material	3
Stainless Steel	SS
Aluminum	AL
Brass	BR
Process Connection	4
1/4" NPT (F)	2MN
1/4" BSP (F)	2MB
Case Filling	5
Dry Case	D
Glycerin Filled	G
Silicone	S
Process Connection Location	6
In-Line	N
Bottom	L
Back	B

Description	Coding
Range	6
Refer to Page 3, Chart 1	
Units	7
Refer to Page 3, Chart 1	
Options	8
5 Point Calibration Certificate	CC
316 L Tag Plate	TP
Dual Scale Marking	DS
Front Flange for Panel Mounting	FF
Back Flange for Surface / Wall Mounting	BF
Panel Mounting Clamp	PM
Colour Banding	CB
Viton O-Rings	VO
EPDM O-Rings	EO
1 SPSTs with a DIN plug	1S
1 SPSTs with Terminal Strip	2S
2 SPSTs with a DIN plug	3S
2 SPSTs with Terminal Strip	4S
1 SPDT with a DIN plug	5S
1 SPDT with Terminal Strip	6S
2 SPDT with a DIN plug	7S
2 SPDT with Terminal Strip	8S

Sample Model Selection Code

1	2	3	4	5	6	7	8					
100	M510	SS	2MN	D	30	PSI	CC	TP	DS	-	-	-

Rev-05.01

Differential Pressure Gauge Standard Ranges

bar	kPa	psi	Kg/cm ²	mbar
0.25	25	-	0.25	250
-	-	5	-	-
0.5	50	8	0.5	500
0.75	75	-	0.75	750
1	100	15	1	1000
-	-	20	-	-
1.6	160	25	1.6	-
2	200	30	2	-
2.5	250	-	2.5	-
3	300	40	3	-
3.5	350	50	3.5	-
4	400	60	4	-
5	500	-	5	-
-	-	80	-	-
6	600	-	6	-
7	700	100	7	-
9	900	-	9	-
10	1000	-	10	-

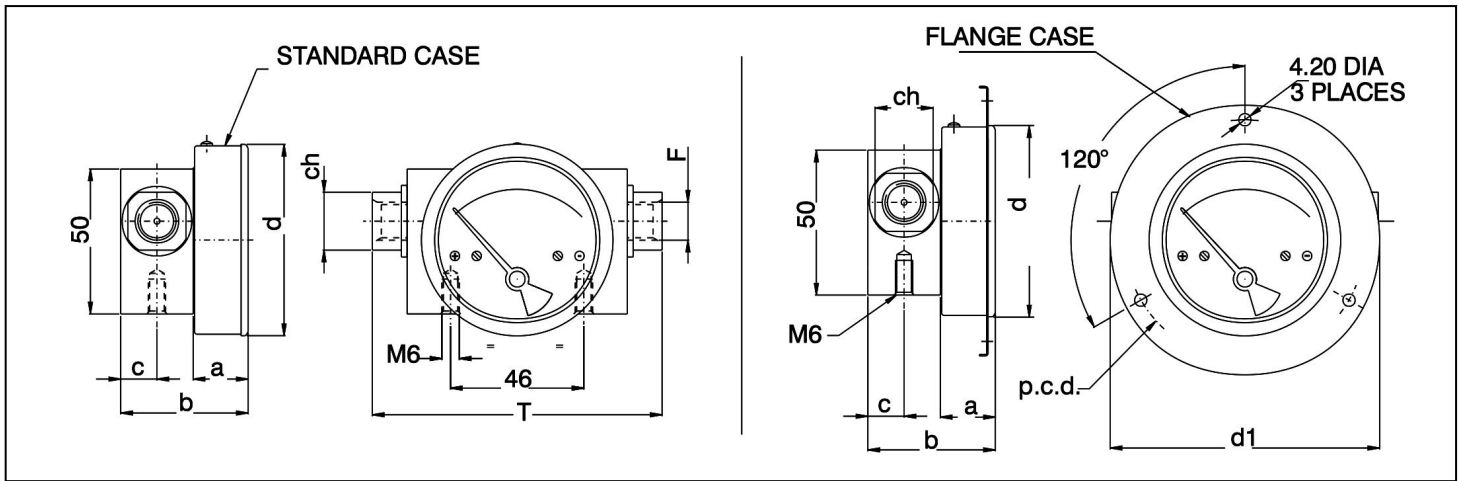

Differential Pressure Gauge Dimensions

Dial	F	a	b	c	d	d1	T	ch	pcd
2" (50 mm)	1/4" BSP - 1/4" NPT	18	43	12.5	53	79	100	20	69
2.5" (63 mm)	1/4" BSP - 1/4" NPT	19	44	12.5	66	93	100	20	83
3" (80 mm)	1/4" BSP - 1/4" NPT	19	44	12.5	83	109	100	20	99
4" (100 mm)	1/4" BSP - 1/4" NPT	19	44	12.5	104.3	131	100	20	121
4.5" (115mm)	1/4" BSP - 1/4" NPT	19	44	12.5	119.7	146	100	20	136
6" (150 mm)	1/4" BSP - 1/4" NPT	19	44	12.5	154.3	181	100	20	171

This page has been internationally left blank

Magwell LLC
537 Cajundome Boulevard, Suite 111
Lafayette, LA 70506

Rev-05.01