

Pressure Digital Test Gauge Model MDT215



Magwell Digital Test Gauge Model MDT215 Series is a powerful Microprocessor based Intelligent Pressure Sensor, which provide high Accuracy and Stability, to calibrate Pressure & Differential Pressure Transmitters, Pressure Gauges, Pressure Switch & other pressure instruments.

Model MDT215 not only has stable performance and fast response time, but also supports a variety of pressure conversion units, but also bluetooth connectivity, displays the ambient Temperature as well Maximum & Minimum Pressure.

Standard Features

- ◆ Pressure Ranges of upto 10,000 psi (700 bar)
- ◆ Dial can be rotated 330°
- ◆ It can record unto 270,000 data, and the datas can be exported through a computer or Bluetooth
- ◆ Power supply - 2 AA battery
- ◆ Backlit Display
- ◆ Displays the Ambient Temperature
- ◆ Split Screen displays Maximum and Minimum Pressure and Range
- ◆ Advanced Temperature Compensation
- ◆ Overload Capacity : 200%
- ◆ Units : kg/cm², inHg, inH₂O, Pa, kPa, MPa, bar, mbar, psi, mmHg, mmH₂O

Specification

Pressure Range :	-15 psi to 10,000 psi
Over load Pressure :	150%
Dial Size :	85 mm
Accuracy :	± 0.2% Full Scale ± 0.5% Full Scale 0.1 10 times/second
Sampling Frequency	-10 ~ +50° C
Ambient Temperature :	-10 ~ +60° C
Operating Temperature :	-20 ~ +70° C
Storage Temperature :	TPE + ABS
Shell Material :	kg/cm ² , inHg, inH ₂ O, Pa, kPa, MPa, bar, mbar, psi, mmHg, mmH ₂ O
Units :	Dual Line, 6 Digits LCD with Backlight
Display :	M20*1.5, 1/4NPT, 1/4BSP, 1/2NPT, 1/2BSP Male
Connection :	Gauge Pressure, Absolute Pressure, Differential Pressure & Compound Pressure
Pressure Types :	330°
Rotation Angle :	IP 65
IP Rating :	0.8 Kg
Weight :	

Accessories Included

Type C Charger Cable
Calibration Certificate
Carry Case
User Manual



 Bluetooth

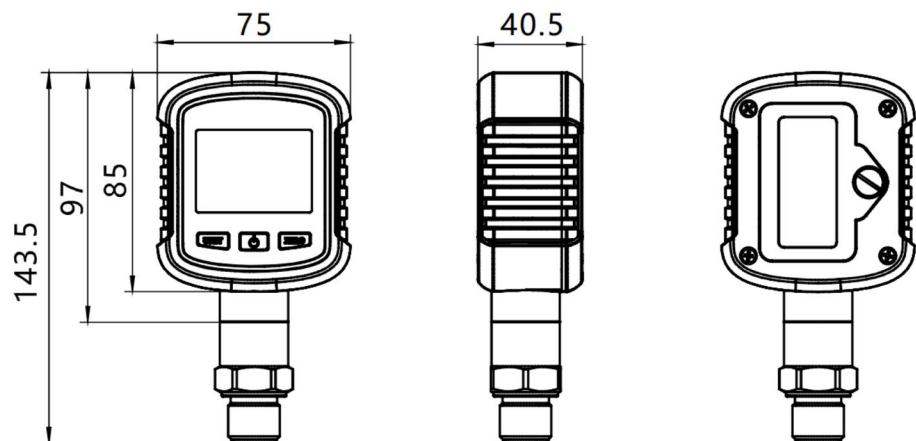



Rev-05.01

Model Selection Guide

Description	Coding
1 Model	
MDT215	
2 Accuracy	
± 0.5% Full Scale	5
± 0.2% Full Scale	2
3 Pressure Range	
Gauge Pressure (Refer Table 1)	
4 Process Connection	
1/4" NPT (M)	2MN
1/4" BSP (M)	2MB
1/2" NPT (M)	4MN
1/2" BSP (M)	4MB
M20*1.5	3MN

Pressure Ranges	
Code	Bar (psi)
P1	-1.0 (-15)
P2	1 (15)
P3	7 (100)
P4	20 (300)
P5	35 (500)
P6	70 (1,000)
P7	140 (2,000)
P8	200 (3,000)
P9	350 (5,000)
P10	700 (10,000)

Optional Accessories			
S.No	Item		Magwell Model
1	High Pressure Hose		MDT-H
2	4 in 1 Pressure Manifold		MDT-4M
3	5 Ports Manifold		MDT-5M

This page has been internationally left blank

Magwell LLC
537 Cajundome Boulevard, Suite 111
Lafayette, LA 70506

Rev-05.01